

Thomson Electrak[®] HD Electric Linear Actuator

Installation Manual

Edition 2016-01

P-264-HD



Version history

Edition	Reason for revision
2016-01	First edition

Warranty

The Thomson Electrak® HD is warranted to be free from defects in materials and workmanship for a period of twelve (12) months from date of delivery. The application of this product is the responsibility of the buyer and Thomson makes no representation or warranty as to the suitability of the product for any particular use or purpose. For a copy of the entire warranty for this product that is contained in our standard terms and conditions of sale, please go to http://www.thomsonlinear.com/website/com/eng/support/terms_and_conditions.php.

Disclaimer

Technical changes to improve the performance of the equipment may be made without prior notice!

All rights reserved. No part of this work may be reproduced in any form (by printing, photocopying, microfilm or any other method) or processed, copied or distributed by electronic means without the written permission of Thomson.

Contents

- 1. General 4**
 - 1.1 About this manual 4
 - 1.2 Target group 4
 - 1.3 Symbols used 4
 - 1.4 Transport and storage 4
 - 1.5 Packaging 4
 - 1.6 Disposal 4
 - 1.7 Support 4

- 2. Safety 5**
 - 2.1 Safety notes 5

- 3. Standards 5**
 - 3.1 EC Declaration of conformity 5

- 4. Installation 6**
 - 4.1 Product label 6
 - 4.2 Terminology 6
 - 4.3 Operation environment 6
 - 4.4 Mechanical installation 7
 - 4.5 Electrical installation 10
 - 4.6 Control options installation and operation 12

- 5. CANBUS information 20**
 - 5.1 Introduction to CANBUS SAE J1939 20
 - 5.2 CANBUS SAE J1939 communications protocol 20

- 6. Technical specifications 24**
 - 6.1 Technical data 24
 - 6.2 Ordering key 25

1. General

1.1 About this manual

This manual contains mechanical and electrical installation instructions for the Thomson Electrak® HD electric linear actuator. It also contains, among other things:

- technical data
- installation data
- type designation key.

It is important to carefully read this manual before installing the actuator and to have the correct qualifications needed to perform the installation.

1.2 Target group

This manual addresses qualified mechanical and electrical personnel.

1.3 Symbols used



This symbol is shown to highlight a general warning, general instruction or as a warning for a mechanical hazard.

1.4 Transport and storage

The actuator may only be transported and stored in the original packaging supplied by Thomson. The temperature during transportation and storage must be between -40 to +85° C (-40 to +185° F). Avoid shocks to the package. If the package is damaged, check the actuator for visible damage and notify the carrier, and if appropriate also Thomson.

1.5 Packaging

The packaging consists of a cardboard box. The box contains the actuator and this manual. For large quantity orders bulk packaging may be used in which case the packaging and the content will vary depending on the order agreement.

1.6 Disposal

Where required by law, used packaging and actuators are taken back by Thomson for professional disposal if the transportation cost is paid by the sender. Please contact Thomson for shipping information.

1.7 Support

If technical support or information is needed for this product, please contact the nearest Thomson Service Center. See the back of this manual. You can also visit www.thomsonlinear.com for information on this product and how to contact us.

2. Safety

2.1 Safety notes



- Only properly qualified personnel are permitted to perform mechanical and electrical installation of this product. Properly qualified personnel are familiar with mechanical or electrical installation work and have the appropriate qualifications for their job.
- Read this manual and any other available documentation before working on the equipment that the actuator is or shall be a part of.
- Conform strictly to the information contained in this manual and on the actuator product label on the actuator. Never exceed the performance limits stated herein.
- Never work on the actuator or its installation with the power on.
- Never unplug any cables or connectors during operation or with power on.
- Immediately stop using the actuator if it seems faulty or damaged in any way and notify an appropriate person so that corrective actions can be taken.
- Never open the actuator as that will compromise the sealing and the function of the actuator. There are no serviceable components inside.
- Grease may be present on the extension tube. Contact is non-hazardous. Film should not be removed.

3. Standards

3.1 EC Declaration of incorporation of partly completed machinery

We, Thomson Linear declare that this product corresponds with the International Standard ISO 13766:2006-05 2nd Edition (Earth Moving Machinery, Electromagnetic Compatibility). The directive (MD) 2006/42/EC annex 2.1.B, RoHSII directive 2011/65/EU, and that the standard EN ISO 12100:2010, Safety of machinery, have been applied.

Thomson Electrak® HD Linear Actuator
.....
Product

HDxxBxxx-xxxxxxxxxxxx
.....
Description

Can be used when the machine or the system, which it shall be, a part of is in accordance with the demands in the EEC Machinery Directive and/or other relevant regulations.

Kristianstad 2016-02-16
.....
Date

Håkan Persson
.....
Name

Business Unit Manager
.....
Title

Håkan Persson
.....
Signature

4. Installation

4.1 Product label

The product label can be found on the side of the cover tube. It will tell you which model of actuator you have, its basic performance data and where it is manufactured. Please study the product label to determine actuator type before starting any installation or service on the actuator. If you need any assistance from Thomson, please provide the serial number, manufacturing date and the designation of the actuator(s) in question. You can also use the QR code on the label to directly access Electrak HD information on www.thomsonlinear.com.

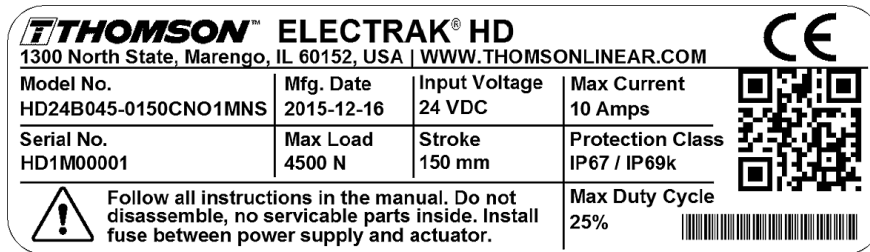

4.2 Terminology

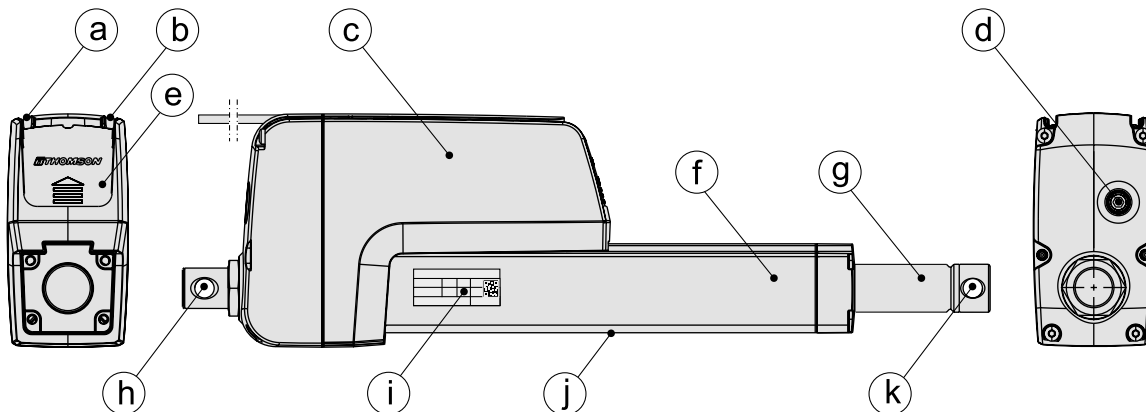

- a. power cable
- b. signal cable
- c. housing
- d. manual override input
- e. cable connector cover plate
- f. cover tube
- g. extension tube
- h. rear adapter
- i. product label
- j. limit switch slots
- k. front adapter

4.3 Operation environment



Min. -40° C (-40° F)



Max. +85° C (+185° F)



IP67 / IP69K

1. Operation temperature range is -40 to +85° Celsius (-40 to +185° Fahrenheit).
2. Protection degree against the ingress of water and particles is IP67 / IP69K.
3. Relative humidity range is 10 - 90 % non-condensing.

4.4 Mechanical installation

4.4.1 General installation safety notes



- Never work on the actuator with the power switched on!
- Do not hold the extension tube while the unit is energized.
- Failure modes of the actuator should be considered to ensure it does not create harm.

4.4.2 Basic installation considerations

1. Only mount the actuator using the holes in the rear (a) and front (b) adapters. Check the model number on the actuator product label (section 4.1) and then look at the ordering key (section 6.2) to find out your adapter type configuration. See the below drawings and table to find out the exact adapter dimensions.
2. Make sure that the actuator mounting position allows access to the cable connector cover plate (c), so that it can be removed to allow access to the cable connector(s) (section 4.4.4).
3. The cable or cables (d) exit the cable slot at the rear of the actuator housing at delivery but can be made to leave the housing at any point after the cable connector cover plate.
4. The manual override input (e) must have enough free space around it to allow it to be operated (section 4.4.5).
5. If external limit switches will be used, the mounting of the actuator must allow access to the limit switch slots (f) running along the underside of the cover tube (section 4.4.6).

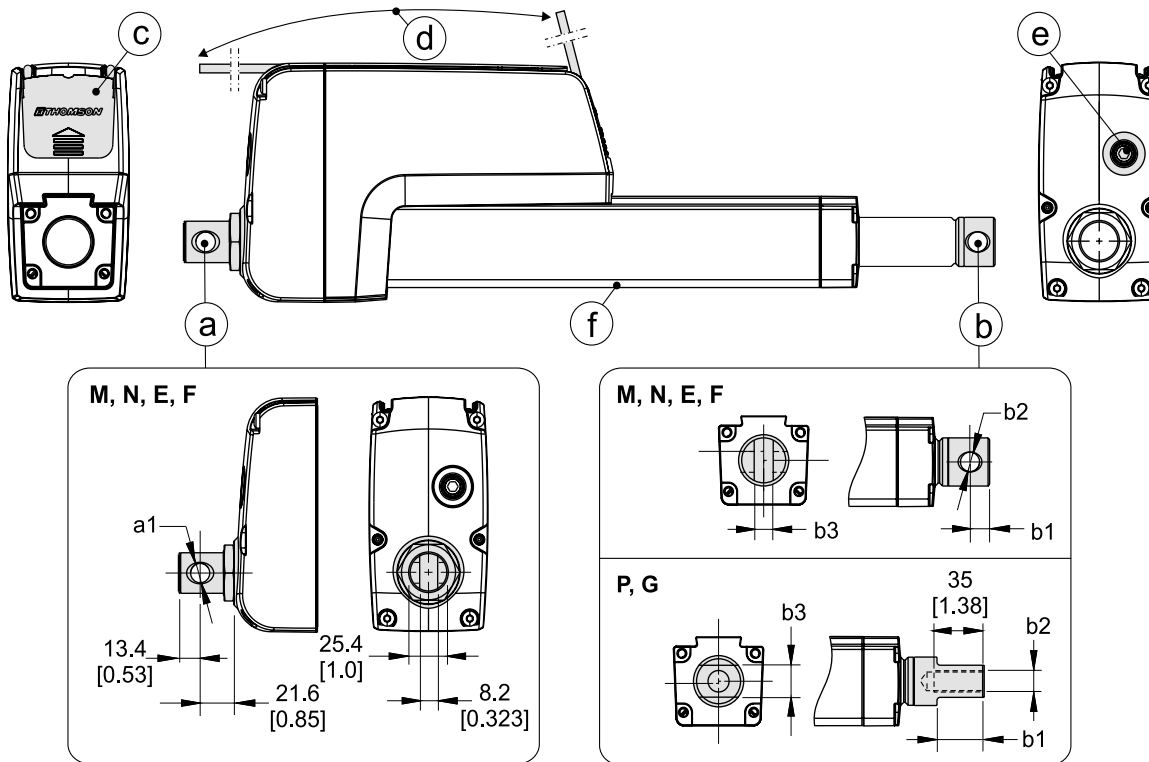

Adapter Dimensions [mm (in)]						
Adapter type						
	M	E	N	F	P	G
a1	12.2 E9 (0.48)	12.8 (0.506)	12.2 E9 (0.48)	12.8 (0.506)	-	-
a2	-	-	8.2 (0.323)	8.2 (0.323)	-	-
b1	10.9 (0.429)	10.9 (0.429)	12.9 (0.508)	12.9 (0.508)	30 (1.18)	30 (1.18)
b2	12.2 E9 (0.48)	12.8 (0.506)	12.2 E9 (0.48)	12.8 (0.506)	M12 × 1.75	1/2-20 NF-2B
b3	-	-	8.2 (0.323)	8.2 (0.323)	19 (0.748)	19 (0.748)

4.4.3 Mounting orientation and forces

1. The actuator can be mounted in any orientation and handle both pushing and pulling loads.
2. Always install actuator so that the force of the load acts in the center of the extension tube and the rear adapter.
3. Only mount the actuator to the rear and front adapter mounting holes.
4. Only use solid mounting pins and support them at both ends.
5. The mounting pins must be parallel to each other both radially and axially.

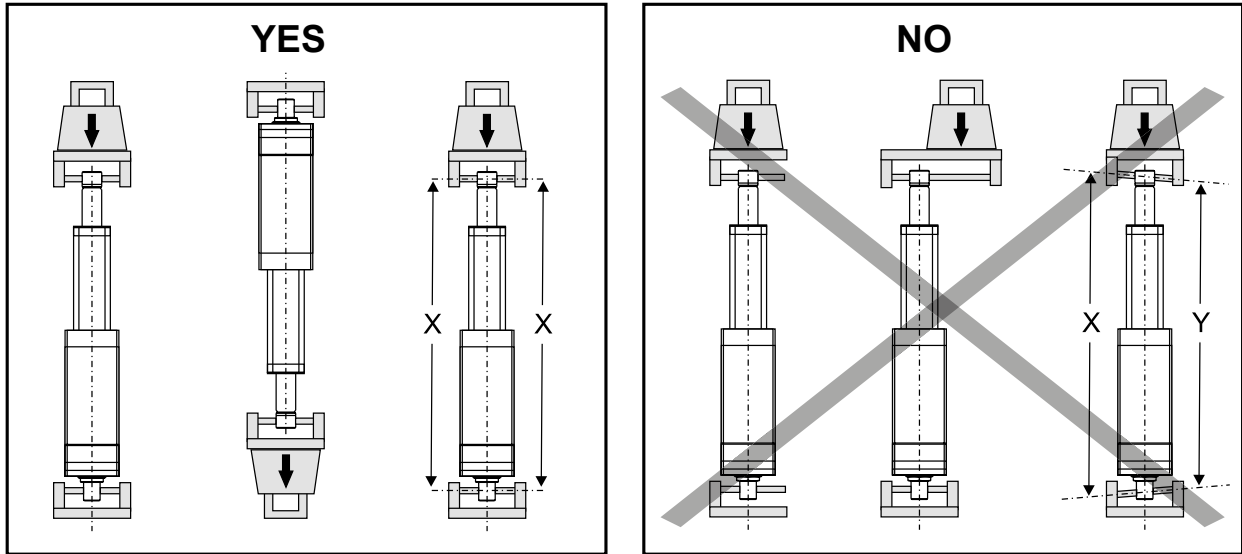

4.4.4 Cable connector cover plate

1. The cover plate is held in place by a screw (M3 with Torx T10 head) that can be accessed through the hole in the top of the cover plate (a). Keep in mind to mount the actuator so that there is enough clearance to access the screw with a tool!
2. Once the cover plate is released it needs to be pushed about 20 mm (0.8 inch) in the direction of the arrow symbol on the cover plate before it can be removed from the actuator (b). The connectors are a part of the backside of the cover plate and can be accessed once the cover plate is removed.
3. Make sure to put the cover plate back correctly and torque the screw to 1.2Nm (10.6 in-lb) to ensure that the actuator cover plate and connectors are properly sealed.

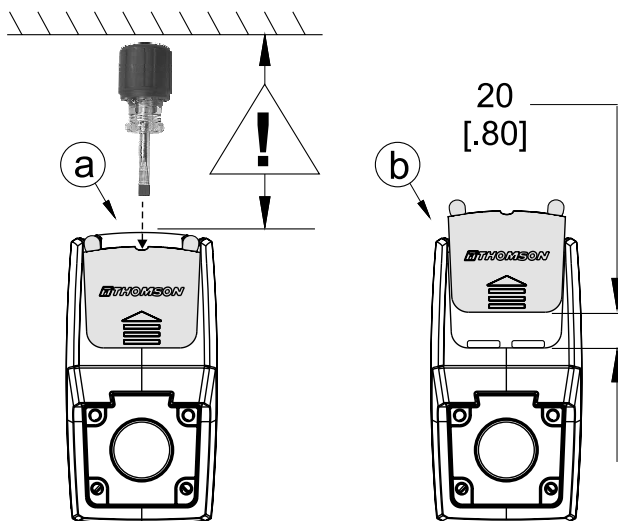

4.4.5 Manual override mounting and operation

1. Make sure when mounting the actuator that there is space enough between the rear adapter and any object behind it to allow the manual override to be operated!
2. To operate the manual override, remove the cover plug (a) using a flat head screw driver. Then turn on the manual override input hexagon key (b) using a 6 mm hexagon deepwall socket (c).
3. The maximum torque required to move the extension tube at the fully rated actuator load using the manual override is typically 1.7 Nm (15 in-lb).
4. The distance the extension tube travels per manual override input revolution depends on the actuator type. See the table below.

Extension Tube Movement / Manual Override Input Revolution [mm (in)]	
Actuator type	Movement
HDxx-B026	0.224 (0.0088)
HDxx-B045	0.134 (0.0053)
HDxx-B068	0.099 (0.0039)
HDxx-B100	0.059 (0.0023)

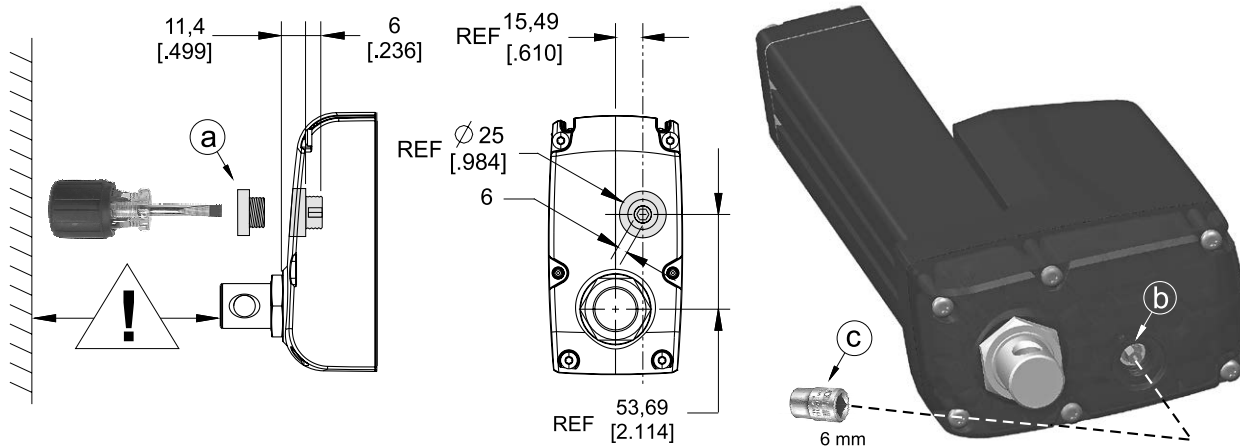

- !** Always make sure to switch off the power to the actuator before using the manual override. Do not apply higher torque than 1.7 Nm (15 in-lb) to the manual override input. Never run the extension tube in to the end of stroke as that may damage the actuator. Never use any type of drill or power tool to operate the manual override.

4.4.6 Mounting of optional external limit switches

1. The external limit switches are mounted in the two slots (a) at the bottom of the cover tube.
2. Put the sensor (b) into one of the slots and and lock it at the desired position by turning the clamp screw 45 degrees (c).

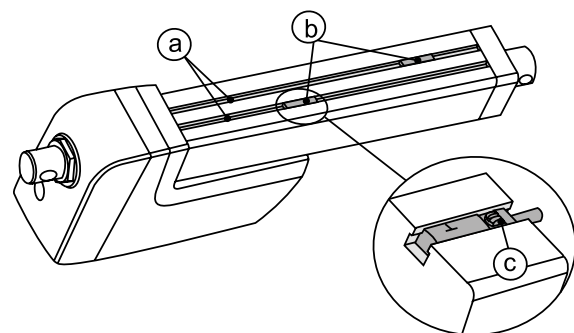

- !** If the sensor is mounted in the immediate vicinity of magnetic components, the switching characteristics of the sensor may change.

4.5 Electrical installation

4.5.1 General notes



- Make sure the leads/cables leading to the motor can handle the maximum motor current.
- An emergency stop is recommended to reduce the chance of a crushing hazard.
- Never work on the actuator or the wiring with the power switched on!

4.5.2 Fuse size

Protect the actuator and the wiring by using a slow blow fuse between the actuator and the power source.

Recommended Fuse Size	
Actuator supply voltage	Fuse size
12 VDC	40 A
24 VDC	20 A

4.5.3 Electrical connections

The actuator is always supplied with a power cable (a). Depending on which control option was selected, it can also have a signal cable (b). The cable(s) have flying leads in one end for customer connections. In the other end the cable(s) are integrated in to the cable connector cover plate (c) (section 4.4.4). The plug in connector allows replacing the actuator without disconnecting the flying leads.

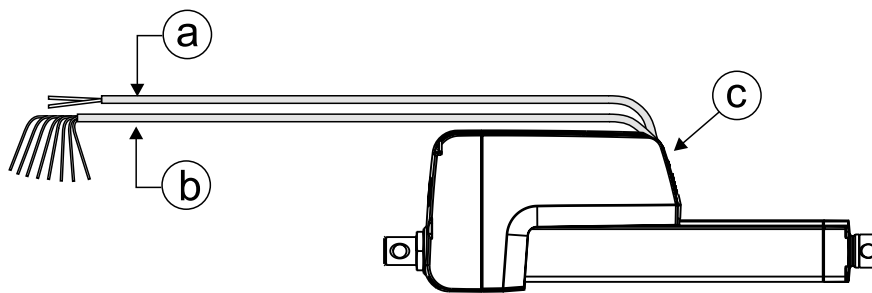

4.5.4 Lead cross sections

To avoid malfunction due to voltage drop the cross section of the leads between the actuator power cable leads and the power source must be of sufficient size. For longer cables than stated in the table, calculations based on the supply voltage, the current draw, the length of the cables and the ambient temperature must be done.

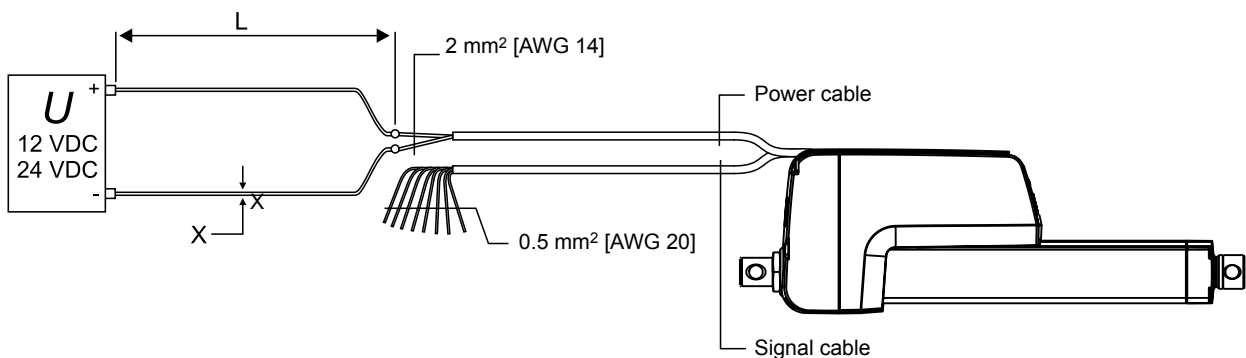

Power Lead Cross Sections	
Length of cable (L)	Min. allowed cross section (X)
0 - 4 m	2.5 mm² [AWG 16]
4 - 10 m	4 mm² [AWG 12]

4.5.5 Inrush current

At the start of the actuator there is an inrush current to the motor that will last between 75 to 150 milliseconds. See below table to determine the inrush current for the control option being used.

Control Option Inrush Current Level	
Option	Inrush current
EXX, ELX, EXP, EXD, ELP, ELD	up to 4 × rated current for the actuator model and load in question
LXX, LLX, LXP, CNO	up to 2 × rated current for the actuator model and load in question



If using an AC powered power supply it must be sized to handle the inrush current (batteries typically have no problem delivering the inrush current). Also contacts, switches and relays must be sized appropriately to be able to handle the inrush current.

4.6 Control options installation and operation

4.6.1 General notes



- Avoid placing signal cables along power cables to reduce the risk of interference.
- Avoid using a vehicle earth as the return conductor. Instead use a two wire system to reduce the risk of interference.
- In very sensitive applications or where there is a risk of interference we recommend using shielded signal cables.
- Keep in mind that long cables in combination with small lead cross sections and low voltages may lead to undervoltage and malfunction due to voltage drop.
- Relays or other coil operated devices should have spark protection to avoid interference.
- Never work on the actuator or the wiring with the power switched on!

4.6.2 How to determine the control option

Electrak HD is equipped with one of the control options in the table below. To determine the option your actuator has, check the model number on the product label on the actuator (section 4.1) and then check the ordering key (section 6.2). Use the table below and go to the corresponding section for further information.

Control Options		
Option	Functions	Section
EXX	Electrak Monitoring Package only	4.6.3
ELX	Electrak Monitoring Package + End of Stroke Indication Output	4.6.4
EXP	Electrak Monitoring Package + Analog Position Output	4.6.5
EXD	Electrak Monitoring Package + Digital Position Output	4.6.6
ELP	Electrak Monitoring Package + End of Stroke Indication Output + Analog Position Output	4.6.7
ELD	Electrak Monitoring Package + End of Stroke Indication Output + Digital Position Output	4.6.8
LXX	Electrak Monitoring Package + Low Level Signal Motor Switching	4.6.9
LLX	Electrak Monitoring Package + Low Level Signal Motor Switching + End of Stroke Indication Output	4.6.10
LXP	Electrak Monitoring Package + Low Level Signal Motor Switching + Analog Position Output	4.6.11
CNO	CAN Bus J1939 Control + Open Loop Speed Control	4.6.12

4.6.3 Control option EXX (Electrak monitoring package only)

Utilizing the internal control system the actuator will:

- Stop the actuator immediately at each end of mechanical travel and throughout the stroke anytime current exceeds a factory preset value for the rated load (over load condition). This value is adjusted during operation automatically to provide consistent force. Resetting the actuator requires motion in opposite direction to continue normal operation.
- Stop the actuator when the current move is finished in the situation where voltage or temperature are outside their normal operating ranges. Once within the normal operating range the actuator will automatically reset and normal operation can be continued.



Always turn power off to the actuator before working on it to eliminate the risk of the actuator making unplanned moves after it has carried out the automatic reset.

To extend the actuator apply +Vdc to red and -Vdc to black. To retract apply -Vdc to red and +Vdc to black.

EXX Control Option Specifications	
Input voltage [Vdc]	
HD12	9 - 16
HD24	18 - 32
Max. actuator current draw [A]	see product label

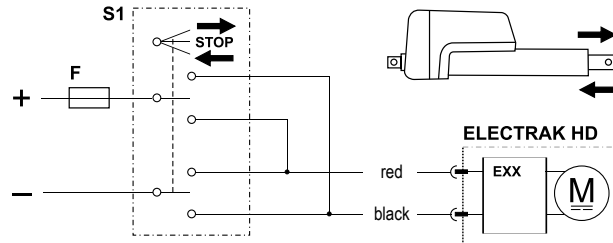

F Fuse

S1 Double pole double throw switch

4.6.4 Control option ELX

In addition to all of the features included in the EXX version (section 4.6.3), the ELX also includes the additional feature of end of stroke indication. These normally open outputs can be used to provide feedback that the actuator has reached it's mechanical minimum or maximum stroke.

To extend the actuator apply +Vdc to red and -Vdc to black. To retract apply -Vdc to red and +Vdc to black.

ELX Control Option Specifications	
Input voltage [Vdc]	
HD12	9 - 16
HD24	18 - 32
Max. actuator current draw [A]	see product label
Output contact type	potential free
Limit switch max. voltage [Vdc]	32
Limit switch max. current [mA]	350
Limit switch max. power [W]	5

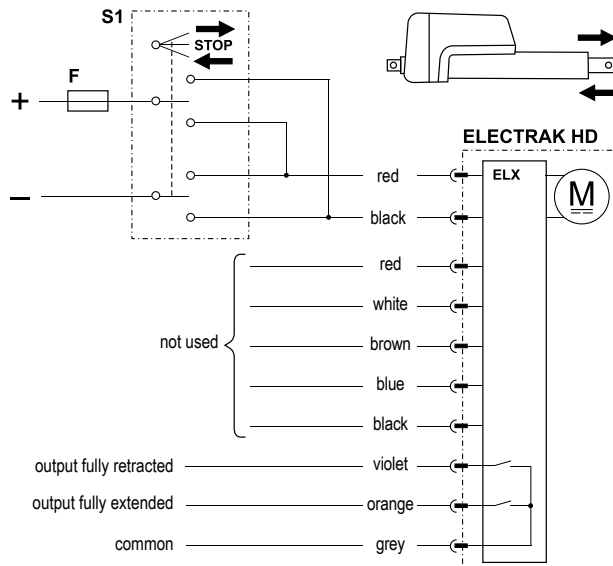

F Fuse

S1 Double pole double throw switch

4.6.5 Control option EXP

In addition to all of the features included in the EXX version (section 4.6.3), the EXP adds a potentiometer providing a voltage signal for the customer to use to determine position, speed and direction.

To extend the actuator apply +Vdc to red and -Vdc to black. To retract apply -Vdc to red and +Vdc to black.

EXP Control Option Specifications		
Input voltage [Vdc]		
HD12		9 - 16
HD24		18 - 32
Max. actuator current draw [A]		see product label
Potentiometer type		wirewound
Potentiometer max. input voltage [Vdc]		32
Potentiometer max. power [W]		1
Potentiometer linearity [%]		± 0.25
Potentiometer output resolution [ohm/mm]		
50 - 100 mm stroke		65.62
150 - 250 mm stroke		32.81
300 - 500 mm stroke		19.69
550 - 1000 mm stroke		9.84

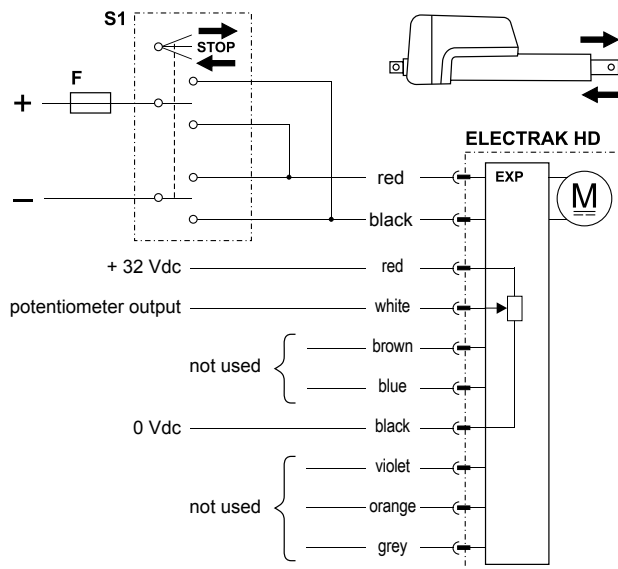

F Fuse
S1 Double pole double throw switch

4.6.6 Control option EXD

In addition to all of the features included in the EXX version (section 4.6.3), the EXD also includes an encoder providing a single pulse train signal to determine position and speed.

To extend the actuator apply +Vdc to red and -Vdc to black. To retract apply -Vdc to red and +Vdc to black.

EXD Control Option Specifications		
Input voltage [Vdc]		
HD12		9 - 16
HD24		18 - 32
Max. actuator current draw [A]		see product label
Encoder type		gear tooth
Encoder input voltage [Vdc]		4 - 24
Encoder output low voltage levels (logical zero) typical / max.		0.1 / 0.25
Encoder resolution [mm/pulse]		
HDxx-B026		0.154
HDxx-B045		0.092
HDxx-B068		0.068
HDxx-B100		0.040

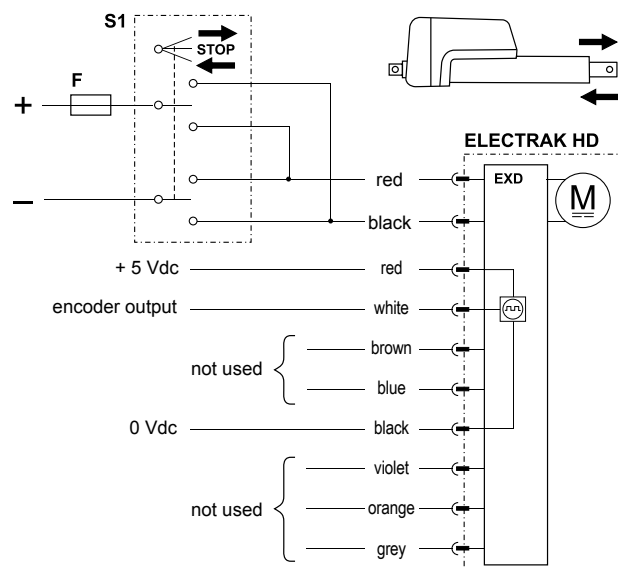

F Fuse
S1 Double pole double throw switch

4.6.7 Control option ELP

In addition to all of the features included in the EXX version (section 4.6.3), the ELP has both end of stroke indication and a potentiometer providing a voltage signal to determine position, speed and direction.

To extend the actuator apply +Vdc to red and -Vdc to black. To retract apply -Vdc to red and +Vdc to black.

ELP Control Option Specifications		
Input voltage [Vdc]		
HD12		9 - 16
HD24		18 - 32
Max. actuator current draw [A]		see product label
Output contact type		potential free
Limit switch max. voltage [Vdc]		32
Limit switch max. current [mA]		350
Limit switch max. power [W]		5
Potentiometer type		wirewound
Potentiometer max. input voltage [Vdc]		32
Potentiometer max. power [W]		1
Potentiometer linearity [%]		± 0.25
Potentiometer output resolution [ohm/mm]		
50 - 100 mm stroke		65.62
150 - 250 mm stroke		32.81
300 - 500 mm stroke		19.69
550 - 1000 mm stroke		9.84

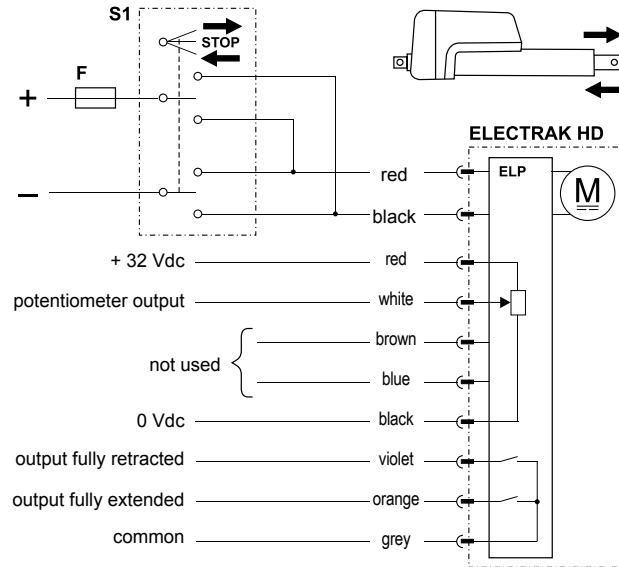

- F Fuse
- S1 Double pole double throw switch

4.6.8 Control option ELD

In addition to all of the features included in the EXX version (section 4.6.3), the ELD has both end of stroke indication and an encoder providing a single pulse train signal to determine position and speed.

To extend the actuator apply +Vdc to red and -Vdc to black. To retract apply -Vdc to red and +Vdc to black.

ELD Control Option Specifications		
Input voltage [Vdc]		
HD12		9 - 16
HD24		18 - 32
Max. actuator current draw [A]		see product label
Output contact type		potential free
Limit switch max. voltage [Vdc]		32
Limit switch max. current [mA]		350
Limit switch max. power [W]		5
Encoder type		gear tooth
Encoder input voltage [Vdc]		4 - 24
Encoder output low voltage levels (logical zero)		
typical / max.		0.1 / 0.25
Encoder resolution [mm/pulse]		
HDxx-B026		0.154
HDxx-B045		0.092
HDxx-B068		0.068
HDxx-B100		0.040

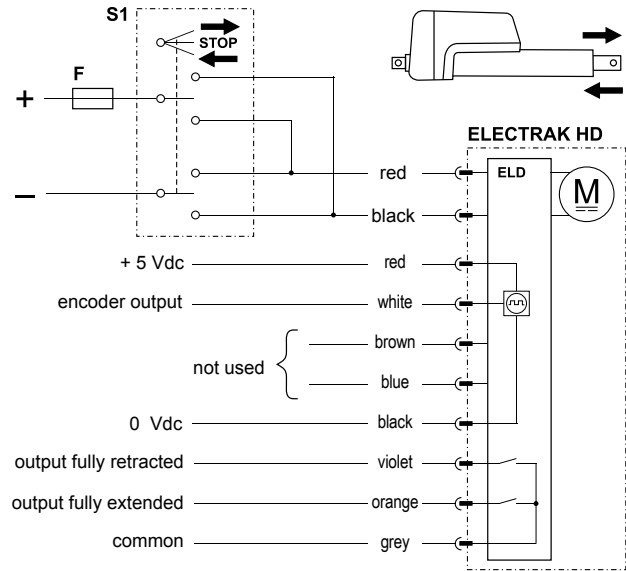

- F Fuse
S1 Double pole double throw switch

4.6.9 Control option LXX

In addition to all of the features included in the EXX version (section 4.6.3), the LXX option allows the end user to extend, retract or stop the actuator using low current (<22 mA) input signals instead of switching the polarity of the input power voltage.

It also includes:

- An automatic soft start capability reducing the inrush current (section 4.5.5).
- A “sleep” mode function is activated when no motion is commanded for 15 seconds. In sleep mode the current draw is less than 1 mA for a 12 Vdc actuator and less the 2 mA for a 24 Vdc actuator. The sleep mode will exit and return to normal operation when the next move command is received.
- Dynamic braking throughout the entire stroke length whenever a motion command is removed.

Power the actuator by connecting red to + Vdc and black to - Vdc in the power cable. To extend the actuator apply +Vdc to violet and to retract apply +Vdc to orange in the signal cable.

LXX Control Option Specifications	
Input voltage [Vdc]	9 - 16 HD12 HD24
Max. actuator current draw [A]	see product label
Extend / retract input voltage [Vdc]	9 - 32
Extend / retract input current [mA]	6 - 22

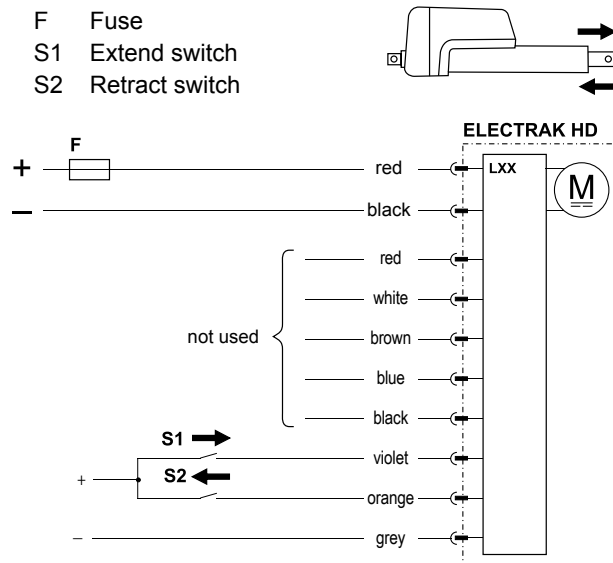

4.6.10 Control option LLX

In addition to all of the features included in the LXX version (section 4.6.9), LLX also includes end of stroke indication. These normally open outputs can be used to provide feedback that the actuator has reached it’s mechanical minimum or maximum stroke.

Power the actuator by connecting red to + Vdc and black to - Vdc in the power cable. To extend the actuator apply +Vdc to violet and to retract apply +Vdc to orange in the signal cable.

LLX Control Option Specifications	
Input voltage [Vdc]	9 - 16 HD12 HD24
Max. actuator current draw [A]	see product label
Output contact type	potential free
Limit switch max. voltage [Vdc]	32
Limit switch max. current [mA]	350
Limit switch max. power [W]	5
Extend / retract input voltage [Vdc]	9 - 32
Extend / retract input current [mA]	6 - 22

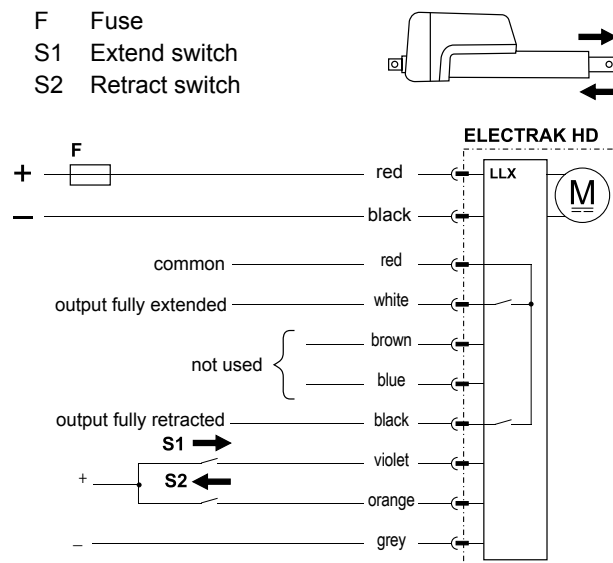

4.6.11 Control option LXP

In addition to all of the features included in the LXX version (section 4.6.9), LXP also includes a potentiometer providing a voltage signal for the customer to use to determine position, speed and direction.

Power the actuator by connecting red to + Vdc and black to - Vdc in the power cable. To extend the actuator apply +Vdc to violet and to retract apply +Vdc to orange in the signal cable.

LXP Control Option Specifications		
Input voltage [Vdc]		9 - 16 18 - 32
Max. actuator current draw [A]		see product label
Potentiometer type		wirewound
Potentiometer max. input voltage [Vdc]		32
Potentiometer max. power [W]		1
Potentiometer linearity [%]		± 0.25
Potentiometer output resolution [ohm/mm]		
50 - 100 mm stroke		65.62
150 - 250 mm stroke		32.81
300 - 500 mm stroke		19.69
550 - 1000 mm stroke		9.84
Extend / retract input voltage [Vdc]		9 - 32
Extend / retract input current [mA]		6 - 22

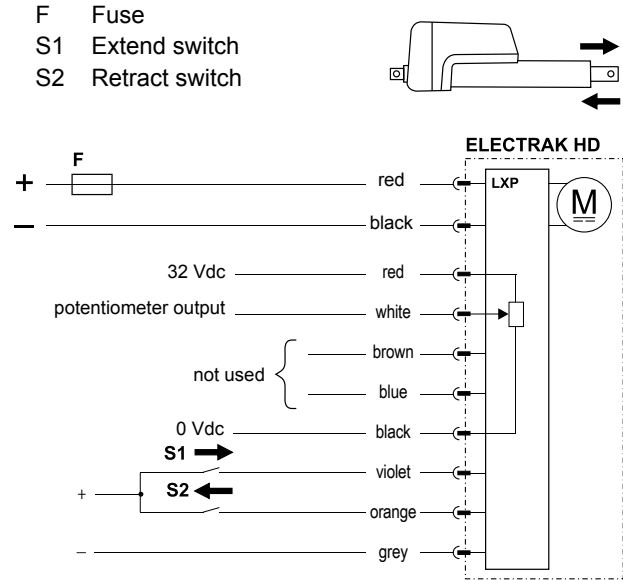

4.6.12 Control option CNO



This document assumes the reader is familiar with the SAE J1939 standard. Terminology from the standard is used, but not described in detail. See section 5 for information on the CAN Bus operation and communication protocol.

4.6.12.1 General installation data

Voltage is to be directly connected to the actuator. All motion and protection on the CAN Bus option is handled through the CAN messages including overload protection. Please see section 5 for more details on the messages.

CNO Control Option Specifications	
Input voltage [Vdc]	9 - 16 HD12 HD24
Max. actuator current draw [A]	see product label

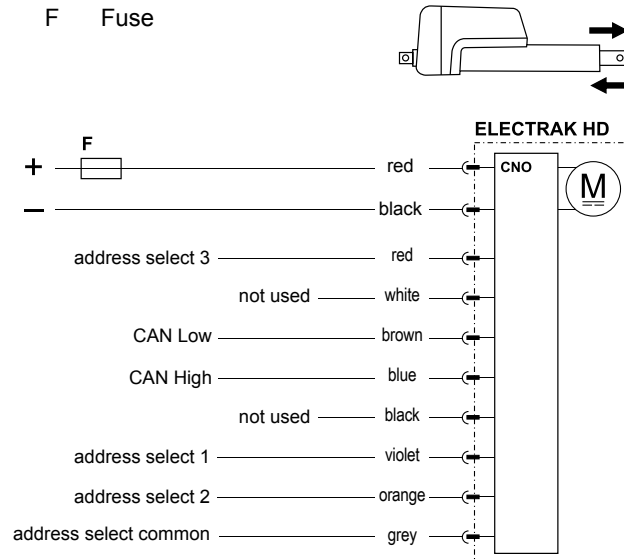

4.6.12.2 CAN Bus SAE J1939 installation data

Follow wiring guidelines per ISO-11898 Standard CAN 2.0B, Protocol SAE J1939. Proper termination resistors (120 Ohm) should be placed in mating wire harness, see below. Please refer to section 5 for more communication details.

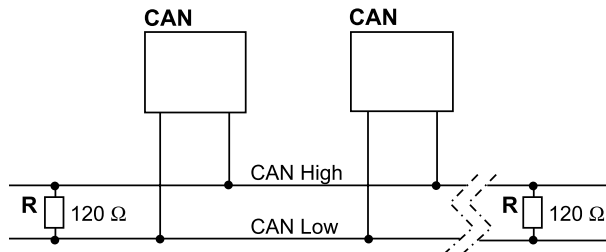

CAN CAN Bus device in actuator or other equipment
 R Resistor

5. CAN Bus information

5.1 Introduction to CANBUS SAE J1939

This document assumes the reader is familiar with the SAE J1939 standard. Terminology from the standard is used, but not described in detail. The Electrak® HD actuator is compliant with the standard J1939, and supports the following PGNs (Parameter Group Number) from the standard.

J1939-21 – Data Link Layer

- Proprietary A 61184 (0x00EF00)
- Proprietary A2 126720 (0x01EF00)

J1939-81 – Network Management

- Address Claimed/Cannot Claim 60928 (0x00EE00)
- Commanded Address 65240 (0x00FED8)

5.2 CANBUS SAE J1939 communications protocol

5.2.1 J1939 NAME

The Electrak HD has the following defaults for the J1939 NAME. Please refer to the SAE J1939/81 standard for more information on these parameters.

J1939 NAME Defaults	
Arbitrary Address Capable	Yes
Industry Group	0, Global
Vehicle System Instance	0
Vehicle System	0, Non-specific system
Function	255, Not available
ECU Instance	0, First instance
Manufacture Code	547, Thomson Linear LLC
Identity Number	0

5.2.2 Address

The Electrak HD uses a default address value of 19 (0x13). In applications where the default address is not available, there are three additional methods in choosing a new address.

1. The Electrak HD device is arbitrary address capable, if another device with a higher priority NAME contends for the selected address, the actuator will continue to request other addresses until it finds one that it can claim.
2. The Electrak HD device can also use the commanded address PGN to select a specified address. See J1939/81 for more details about address claiming.
3. In some applications it may be more convenient to select an address through hardware means. In this case the user can change the default address using the address select wires as defined in section 4.6.12. Activating individual select pins will create a binary adder to the default address. This method can allow up to 8 individual actuator addresses on a single bus. The below chart shows some examples on how this can be implemented.

Address Select					
Address select common	Address select 3	Address select 2	Address select 1	Binary adder	Default address
Gnd	0	0	0	0	19 (0x13)
Gnd	0	0	1	1	20 (0x14)
Gnd	0	1	0	2	21 (0x15)
...					
Gnd	1	1	1	7	26 (0x20)

5.2.3 Sleep operation

The Electrak HD utilizes a sleep mode operation when positioning is no longer required. This feature allows for a constant battery connection with minimal drain while the engine or vehicle is not running. After 5 seconds of bus inactivity, the actuator will put itself in a state of sleep. During this state the quiescent current is <1 mA for 12 Vdc models and <2 mA for 24 Vdc models. When bus activity is restored the actuator will begin a wake up phase, followed by an address claim request.

5.2.4 J1939 actuator control message (ACM)

All actuator control parameters are adjustable through the proprietary A message (PGN 61184). The preferred transmission repetition rate is 100ms (can also be sent as required by the application.) Additional message specific information can be found in the table below, all other Proprietary A information can be found in the SAE J1939/21 specification.

Actuator Control Message Signal Information		
Start position	Length	Parameter name
1.1	14 bits	Position command
2.7	9 bits	Current limit
3.8	5 bits	Speed command
4.5	1 bit	Motion enable
4.6	35 bits	Factory use

The least significant bit of each message is indicated by the start position column

5.2.4.1 Position command

This 14-bit signal is used to set the target position for the next actuator motion. Although resolution of the signal is represented as 0.1 mm/bit, true positional accuracy will be dependent on the stroke length of the given model. The actuator uses an internally calculated deadband value to determine when within a target position range. The 0.0 mm and full extend stroke values represent 0 to 100% stroke and are only relative to the actual available stroke of the individual unit.

Range: 0.0 mm to 1000.0 mm
Resolution: 0.1 mm/bit, 0 offset

5.2.4.2 Current limit

This 9-bit signal is used to set a current at which the actuator will cease motion. In the event a force is applied to the actuator that causes the motor current to exceed this settable value for more than 50 ms, the actuator will stop any current motion and activate a dynamic breaking effect on the motor. This current limit does not apply during the motor starting phase where in rush current can be significantly higher than normal running.

Range: 0.0 A to 25.0 A (12Vdc actuator), 0.0A to 12.5 A (24Vdc actuator)
Resolution: 0.1 A/bit, 0 offset

5.2.4.3 Speed command

This 5-bit signal is used to set the speed of the actuator. The signal adjusts the PWM driver within the actuator and the voltage applied to the motor. The resultant actuator speed will be a ratio of the actuators max speed and also dependent on the load applied to the actuator.

Range: 0% to 100% motor duty cycle
Resolution: 5%/bit, 0 offset

5.2.4.4 Motion enable

This 1-bit signal is used to enable motion from the actuator. If this bit is low (0), no motion will be allowed. This signal can be used to define the next actuator movement message without starting the motor. When movement is required this bit can be changed to high (1) and motion will begin using the other parameter signals encoded in the ACM.

5.2.4.5 Factory use

The remaining 35 bits of the ACM are used for factory calibration use only and should be filled with 0x00 or 0xFF when sending this message.

5.2.5 J1939 actuator feedback message (AFM)

All actuator feedback data can be retrieved through the proprietary A2 message (PGN 126720). This message is transmitted every 100ms. Additional message specific information can be found in Table 2, all other Proprietary A2 information can be found in the SAE J1939/21 specification.

Actuator Feedback Message Signal Information		
Start position	Length	Parameter name
1.1	14 bits	Measured position
2.7	9 bits	Measured current
3.8	5 bits	Running speed
4.5	2 bits	Voltage error
4.7	2 bits	Temperature error
5.1	1 bit	Motion flag
5.2	1 bit	Overload flag
5.3	1 bit	Backdrive flag
5.4	1 bit	Parameter flag
5.5	1 bit	Saturation flag
5.6	1 bit	Fatal error flag
5.7	18 bits	Factory use

The least significant bit of each message is indicated by the start position column

5.2.5.1 Measured position

This 14-bit signal is used to inform the user of the actual actuator stroke position. Although resolution of the signal is represented as 0.1 mm/bit, true positional accuracy will be dependent on the stroke length of the given model. The actuator uses an internally calculated deadband value to determine when it is within a target position range. The 0.0 mm and ordered full extend stroke values represent 0 to 100% stroke but the signaled value does not take in to account any mechanical tolerances or play in the actuator.

Range: 0.0 mm to 1000.0 mm

Resolution: 0.1 mm/bit, 0 offset

5.2.5.2 Measured current

This 9-bit signal is used to inform the user of the actual current being drawn used by the actuator.

Range: 0.0 A to 51.1 A

Resolution: 0.1 A/bit, 0 offset

5.2.5.3 Running speed

This 5-bit signal is used to inform the user of the actual duty cycle being applied to the motor through the internal actuator controller.

Range: 0% to 100% motor duty cycle

Resolution: 5%/bit, 0 offset

5.2.5.4 Voltage error

This 2-bit signal is used to inform the user that the operational voltage is outside of allowable running parameters. Any motion already in progress will continue until completed, but additional movement request will not be allowed until the operational voltage returns within the normal operating range.

Voltage Error Message	
00	Input voltage within operational range
01	Input voltage below operational range
10	Input voltage above operational range
11	Not used

5.2.5.5 Temperature error

This 2-bit signal is used to inform the user that the operational temperature is outside of allowable running parameters. Any motion already in progress will continue until completed, but additional movement request will not be allowed until the operational temperature returns within the normal operating range.

Temperature Error Message	
00	Temperature within operational range
01	Temperature below operational range
10	Temperature above operational range
11	Not used

5.2.5.6 Motion flag

This 1-bit signal is used to inform the user that the actuator is currently in motion.

5.2.5.7 Overload flag

This 1-bit signal is used to inform the user that the last motion the actuator completed caused a current over load condition. This occurs when the actuator determines the current set in the Current Limit signal from the ACM is exceeded for a consecutive 50ms. When this flag is set by the actuator the user must reset the Motion Enable flag in the ACM before attempting additional motion from the actuator.

5.2.5.8 Backdrive flag

This 1-bit signal is used to inform the user that the actuator has determined positional movement in the extension tube that was not commanded from the user. This can be caused from excessive static load or vibration being applied to the actuator.

5.2.5.9 Parameter flag

This 1-bit signal is used to inform the user that one of the parameter signals in the ACM is outside the allowed parameters the specific model will allow. To prevent damage to the actuator motion is not allowed while this flag is set.

5.2.5.10 Saturation flag

This 1-bit signal is used to inform the user that the actuator is currently running within 10% of its maximum capability. Additional speed or current needed from the application may not be able to be obtained with the chosen actuator model.

5.2.5.11 Fatal error flag

This 1-bit signal is used to inform the user that the actuator needs service. If this flag is set power can be reset to determine if the flag is resettable, but it is suggested to contact the factory for additional support. To prevent possible additional damage motion is prohibited while this flag is set.

5.2.5.12 Factory use

The remaining 18 bits of the Actuator Feedback Message are used for factory calibration use only and under normal operation will be returned with 0x00.

6. Technical specifications

6.1 Technical data

Technical Specification		HD • •	
Input voltage	[VDC]	12	24
Input voltage tolerance	[VDC]	9 - 16	18 - 32
Stroke length	[mm]	see product label	
Static load at fully retracted (Fx), maximum	[kN (lbs)]	18 (4050)	
Dynamic load (Fx), maximum	[N]	see product label	
Speed, no load / max. rated load	[mm/s (inch/s)]		
HDxx-B026		40 / 32 (1.6 / 1.3)	
HDxx-B045		24 / 19 (0.94 / 0.75)	
HDxx-B068		18 / 14 (0.71 / 0.55)	
HDxx-B100		11 / 9 (0.43 / 0.35)	
Current draw @ rated max. load	[A]	see product label	
Weight	[kg (lbs)]	see table below	
End play, maximum	[mm (in)]	1.2 (0.047)	
Operating temperature limits, standard units	[°C (°F)]	- 40 to + 85 (- 40 to + 185)	
Full load duty cycle @ 25 °C	[%]	see product label	
Restraining torque	[Nm (lbf-in)]	0 (internally restrained)	
Motor cable lead cross section	[mm ² (AWG)]	2 (14)	
Signal cable lead cross section	[mm ² (AWG)]	0.5 (20)	
Cable length (depending on option)	[mm (in)]	0.3 (11.8), 1.5 (59) or 5 (197)	
Protection class - static		IP67 / IP69K	
Protection class - dynamic		IP66	
Safety features			
static load holding brake		yes	
internal end-of-stroke limit switches		yes	
overload protection		yes	
temperature monitoring		yes	
temperature compensation		yes	
voltage monitoring		yes	
Certifications		CE, RoHS	

Actuator Weight [kg]*																				
Actuator model	Stroke (see product label) [mm]																			
	100	150	200	250	300	350	400	450	500	550	600	650	700	750	800	850	900	950	1000	
HDxx-B026	6.5	6.7	7.0	7.2	7.5	7.7	8.0	8.2	8.5	8.7	9.0	9.2	9.5	9.7	10.0	10.2	11.6	11.9	12.2	
HDxx-B045	6.5	6.7	7.0	7.2	7.5	7.7	8.0	8.2	8.5	8.7	9.0	9.2	10.4	10.7	11.0	11.3	11.6	11.9	12.2	
HDxx-B068	6.5	6.7	7.0	7.2	7.5	7.7	8.0	8.2	8.5	9.5	9.8	10.1	10.4	10.7	11.0	11.3	11.6	11.9	12.2	
HDxx-B100	6.7	7.0	7.2	7.5	7.7	8.0	8.2	9.1	9.4	9.7	10.0	10.3	10.6	10.9	11.2	11.5	11.8	12.1	12.4	

* Conversion factor for kilogram to pound: 1 kg = 2.204623 lbs

6.2 Ordering key

Ordering Key								
Position	1	2	3	4	5	6	7	8
Example	HD12	B026-	0300	LXX	2	M	M	S
<p>1. Actuator type and supply voltage HD12 = Electrak HD, 12 Vdc HD24 = Electrak HD, 24 Vdc</p> <p>2. Screw type, dynamic load capacity B026- = ball screw, 2.6 kN (585 lbs) B045- = ball screw, 4.5 kN (1012 lbs) B068- = ball screw, 6.8 kN (1529 lbs) B100- = ball screw, 10 kN (2248 lbs)</p> <p>3. Ordering stroke length 0100 = 100 mm 0150 = 150 mm 0200 = 200 mm 0250 = 250 mm 0300 = 300 mm 0350 = 350 mm 0400 = 400 mm 0450 = 450 mm 0500 = 500 mm 0550 = 550 mm 0600 = 600 mm 0650 = 650 mm 0700 = 700 mm 0750 = 750 mm 0800 = 800 mm 0850 = 850 mm 0900 = 900 mm 0950 = 950 mm 1000 = 1000 mm</p>				<p>4. Electrak® Modular Control System options EXX = Electronic Monitoring Package only ELX = EXX + end-of-stroke indication output EXP = EXX + analog (potentiometer) position output EXD = EXX + digital position output ELP = ELX + analog (potentiometer) position output ELD = ELX + digital position output LXX = EXX + low-level signal motor switching LLX = EXX + LXX + end-of-stroke indication output LXP = EXX + LXX + analog (potentiometer) position output CNO = Can bus J1939 + open loop speed control</p> <p>5. Harness option 1 = 0.3 m long cables with flying leads 2 = 1.5 m long cables with flying leads 3 = 5.0 m long cables with flying leads</p> <p>6. Rear adapter option M = cross hole for 12 mm pin E = cross hole for ½ inch pin N = forked cross hole for 12 mm pin F = forked cross hole for ½ inch pin</p> <p>7. Front adapter option M = cross hole for 12 mm pin E = cross hole for ½ inch pin N = forked cross hole for 12 mm pin F = forked cross hole for ½ inch pin P = metric female thread G = inch female thread</p> <p>8. Adapter orientation S = standard M = 90 ° turned</p>				

USA, CANADA and MEXICO

Thomson
203A West Rock Road
Radford, VA 24141, USA
Phone: 1-540-633-3549
Fax: 1-540-633-0294
E-mail: thomson@thomsonlinear.com
Literature: literature.thomsonlinear.com

EUROPE**United Kingdom**

Thomson
Phone: +44 (0) 1271 334 500
Fax: +44 (0) 1271 334 501
E-mail: sales.uk@thomsonlinear.com

Germany

Thomson
Nürtinger Straße 70
72649 Wolfschlugen
Phone: +49 (0) 7022 504 0
Fax: +49 (0) 7022 504 405
E-mail: sales.germany@thomsonlinear.com

France

Thomson
Phone: +33 (0) 243 50 03 30
Fax: +33 (0) 243 50 03 39
E-mail: sales.france@thomsonlinear.com

Italy

Thomson
Largo Brughetti
20030 Bovisio Masciago
Phone: +39 0362 594260
Fax: +39 0362 594263
E-mail: info@thomsonlinear.it

Spain

Thomson
Rbla Badal, 29-31 7th, 1st
08014 Barcelona
Phone: +34 (0) 9329 80278
Fax: + 34 (0) 9329 80278
E-mail: sales.esm@thomsonlinear.com

Sweden

Thomson
Estridsväg 10
29109 Kristianstad
Phone: +46 (0) 44 24 67 00
Fax: +46 (0) 44 24 40 85
E-mail: sales.scandinavia@thomsonlinear.com

ASIA**Asia Pacific**

E-mail: sales.apac@thomsonlinear.com

China

Thomson
Rm 2205, Scitech Tower
22 Jianguomen Wai Street
Beijing 100004
Phone: +86 400 6661 802
Fax: +86 10 6515 0263
E-mail: sales.china@thomsonlinear.com

India

Thomson India
1001, Sigma Building
Hiranandani Business Park
Powai, Mumbai – 400076
Phone: +91 22 422 70 300
Fax: +91 22 422 70 338
E-mail: sales.india@thomsonlinear.com

Japan

Thomson
Minami-Kaneden 2-12-23, Suita
Osaka 564-0044
Phone: +81-6-6386-8001
Fax: +81-6-6386-5022
E-mail: csinfo_dicgj@danaher.co.jp

South Korea

Thomson
F12 Ilsong Bldg, 157-37
Samsung-dong, Kangnam-gu
Seoul (135-090)
Phone: +82 2 6917 5049
Fax: +82 2 6917 5007
E-mail: sales.korea@thomsonlinear.com

SOUTH AMERICA**Thomson**

Sao Paulo, SP Brasil
Phone: +55 11 3616 0191
Fax: +55 11 3611 1982
Email: sales.brasil@thomsonlinear.com